



Log wood and combined boilers

15–50 kW



Over **40** years of experience and competence

Heating with wood

The use of wood in forests is sustainable.

For over 300 years, more wood has been growing than is being used.

Log wood is the most important renewable energy source for heat generation.

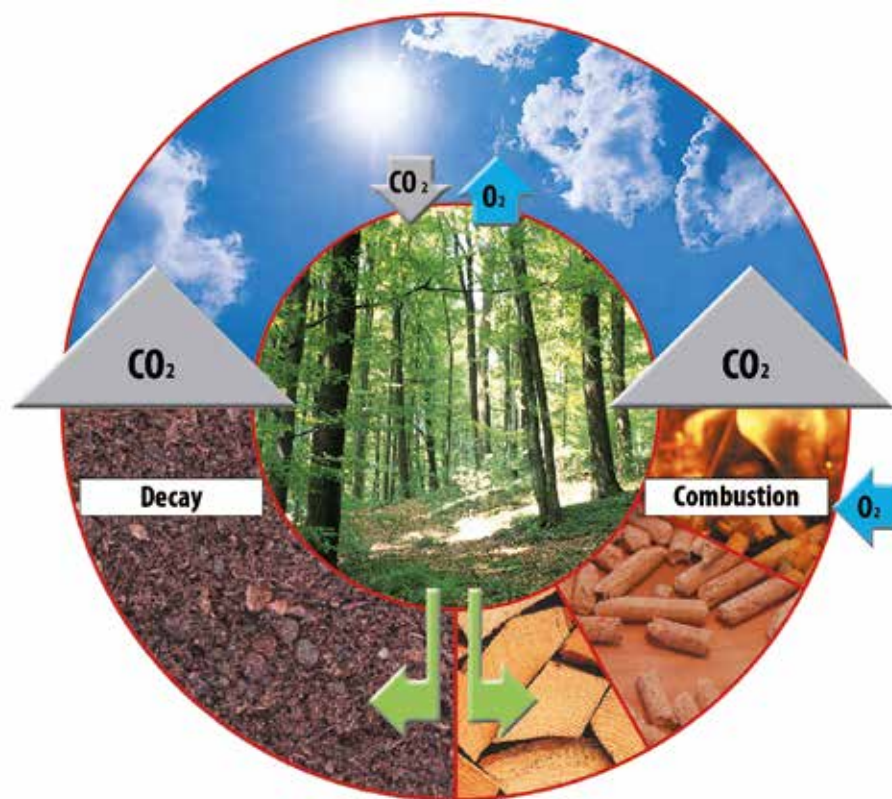

During growth, trees need CO_2 , which they take from the air and store in the wood or leaf mass. When wood is burnt, CO_2 is released – but only as much as the tree has removed from the atmosphere in the course of its growth.

Anyone who heats with wood is therefore heating sustainably in the cycle of nature, i.e. the heating is CO_2 neutral.

Heating with wood also has many advantages over fossil fuels:

- Short transport routes
- Independence and security of supply
- Safe storage and transport
- Employment and value creation in the region
- Harvesting and preparation requires little energy

"We heat with wood. This protects the environment and helps us to reliably plan our energy costs for the future."

Birgit and Josef Hausperger



Making the most of log wood potential

As a someone who heats with wood, you can have an enormous influence on the economy, emission behaviour and service life of your boiler.

With an HDG log wood boiler...

- you can heat in a way that is both efficient and environmentally friendly
- you lower your fuel consumption
- you need to heat your space less often
- you create maximum comfort, e.g. through the automatic ignition and cleaning system
- you can use other fuels, e.g. wood chips, pellets or even oil

Tips on using log wood as a fuel



- Firewood should mainly be cut during the winter months. Split the firewood as soon as possible after cutting. This makes it dry out quicker. Furthermore, wood that is fresh from the forest is easier to split.
- Ideally, you should match the size of the logs to your firing system right away. This reduces the water content to below 20% even faster and produces a firewood quality that is ready for the stove.
- Wet wood burns with a significantly lower energy efficiency and can lead to higher emissions as well as aggressive deposits.

Abbreviations of cubic measures:

- 1 Srm = fill volume unit,
corresponds to 1 m³ wood (tipped)
- 1 Rm = stacked cubic meter (stere),
corresponds to 1 m³ wood (stacked)
- 1 Fm = 1 solid cubic metre
(without intermediate spaces)

Conversion factors:

- 1 l heating oil gives off 2.676 kg of CO₂ during combustion
- 1 l heating oil corresponds to 2.5 kg wood (with a 20% water content)

1000 l of heating oil yields the same energy as:

- approx. 5–6 m³ hardwood
- approx. 7–8 m³ softwood
- approx. 10–15 Srm wood chips

Condition of the wood	Water content (w)	Calorific value (Hu)
freshly cut	50–60%	2.0 kWh/kg = 7.2 MJ/kg
stored over a summer	25–35%	3.4 kWh/kg = 12.2 MJ/kg
stored for several years	15–25%	4.0 kWh/kg = 14.4 MJ/kg

HDG H

The independent one

20 kW, 25 kW, 30 kW

- Log wood (half a metre)
- Can be expanded with oil burner



10–13

HDG R

The simple one

15 kW

- Log wood (a third of a metre)



6–9

HDG The company

32–35



Comfortable
Heating. With Wood!



HDG Euro The all-rounder

30 kW, 40 kW, 48 kW

- Log wood (half a metre)
- Waste wood
- Wood chips
- Shavings
- Pressed wood briquettes

14–17



HDG F The convenient one

20 kW, 25 kW, 30 kW, 40 kW, 50 kW

- Log wood (half a metre)

18–21



HDG FK Hybrid Log wood/pellet combination

The flexible one

15–50 kW

- Log wood (half a metre)
- Pellets

22–25

HDG R

The HDG R is a gasifying wood boiler with downward combustion technology. The boiler is perfect for use as a supplementary boiler for existing oil, gas or pellet boilers. The HDG R is also used with heat pumps or solar systems, which are often used in low-energy housing, and delivers both economic advantages and additional safety.

Output:
15 kW

A+

Application range:

- Single-family homes
- Ideal as an additional boiler*



Fuels:

- Log wood (a third of a metre)**

* The annual running time is expected to be no more than 800 hours.
** A maximum hardwood content of 30 percent is recommended for the fuel. Otherwise, this will result in greater wear to the boiler.

The simple one



"Our installer recommended HDG to us. We are very satisfied. The HDG R meets our expectations."

Kozisnik family



The highlights

✓ Practical

- Can be used in almost any boiler room thanks to the space-saving dimensions and compact design
- Additional protection and easy movement of the fuel with the help of the edged panels in the fuel chamber



✓ User-friendly

- Clean and odourless conditions in the boiler room when opening the fuel chamber door thanks to integrated flue gas extraction



- Flexible installation options thanks to replaceable door hinge (optional)
- Less frequent cleaning thanks to large and easily accessible cleaning openings

✓ Efficient

- Consistently high efficiency thanks to the cleaning turbulators supplied as standard



- Lowest emissions thanks to clean recombustion in the high-temperature combustion chamber



- Simple adjustment of the combustion air volume depending on the type of wood

✓ Economical

- Ideal as an additional boiler, e.g. for an existing oil/gas boiler
- Not affected by energy price fluctuations or air or ground source systems.

✓ HDG Easy-Control

- Simple operation via large display with self-explanatory menu navigation
- Flue-gas- and boiler-temperature-controlled combustion and power control via speed-controlled flue gas fan
- Safe operation of the heating system with display of the refuel signal or enabling of an oil/gas boiler
- Control of the return temperature control with residual heat utilisation



HDG R

Cross-section

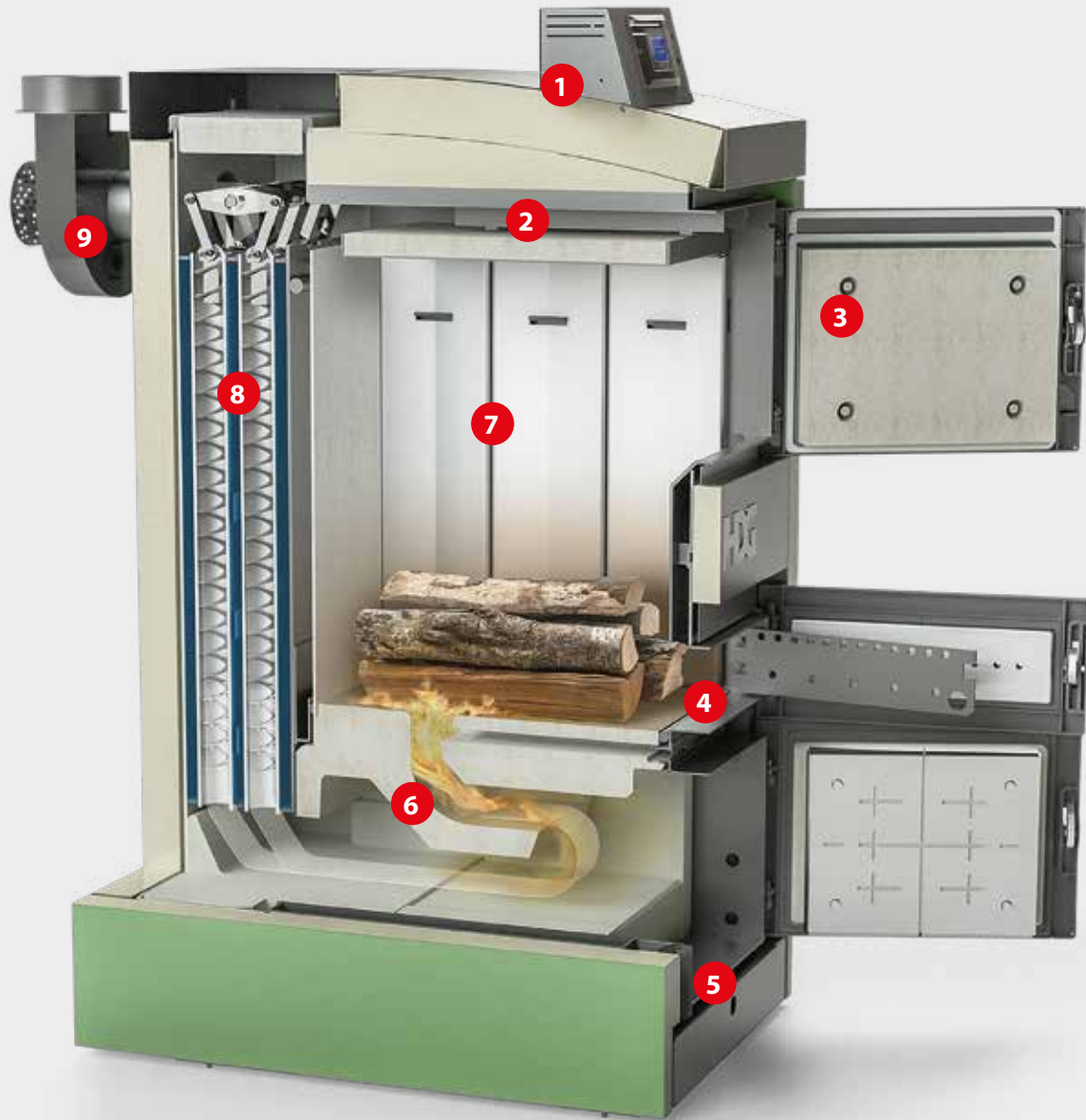

- 1 Intuitive HDG Easy-Control
- 2 Flue gas duct for extracting the carbonisation gases in the fuel chamber
- 3 Large fuel chamber door for particularly ergonomic filling
- 4 Adjustable air openings depending on the type of wood
- 5 Integrated ash pan for effortless disposal of combustion residues
- 6 Modular combustion chamber for low-emission recombination of the fuel gases
- 7 Edged panels for easy fuel movement
- 8 Cleaning turbulators for consistently high efficiency
- 9 Speed-controlled flue gas fan for clean combustion

Technical data

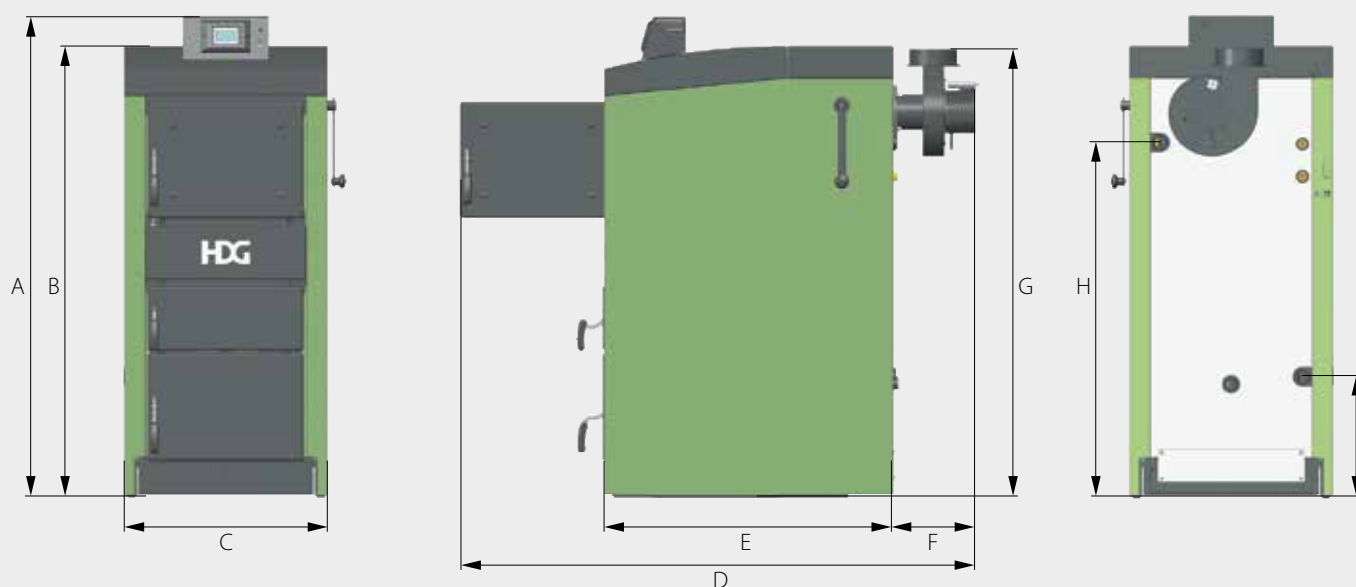

Dimensions (in mm)	Designation	HDG R15
A	Height of boiler with controller	1440
B	Height of boiler without controller	1350
C	Width of boiler (without actuation of cleaning system)	630
D	Total length with open fuel chamber door including flue gas fan	1400
E	Length of boiler without attachments and flue gas pipe connection	720
F	Flue gas fan overhang	230
G	Height of flue gas pipe connection	1340
H	Height at middle of supply connection	1050
I	Height at middle of return connection	375
	min. installation dimensions (without cladding and attachments)	730 x 630 x 1310

Boiler type	Unit	HDG R15
Nominal thermal power	kW	15
Fuel chamber capacity	l	65
Fuel chamber depth	mm	360
Dimensions of fill opening (width x height)	mm	390 x 300
Required auxiliary energy	W	15
Diameter of flue gas pipe connection	mm	130
Flue draught requirement (Pw)	Pa	6
Total weight	kg	480
Boiler energy efficiency class		A+
Boiler + controller energy efficiency class (class VI)		A+

HDG H

The independent one

HDG continues the technology that has proven itself for decades in the field of combined boilers. The HDG H is a variable gasifying wood boiler with bottom lateral burning cycle. If necessary, the boiler can be expanded with an oil burner unit. This makes it possible to choose a cost-effective fuel depending on the market situation. This boiler is therefore ideal for partial renovation of a heating system.

Output:

20 kW, 25 kW, 30 kW



Application range:

- Single-family homes
- Apartment buildings
- Agricultural enterprises



Fuels:

- Log wood (half a metre)
- Oil (optional)



"We were looking for a heating system that could run on log wood, oil and solar thermal energy. This degree of flexibility was extremely important to us. When it comes down to it, the only real option is an H-boiler from HDG."

Hammann family



The highlights

✔ Convenient

- Ideal fuel quantity and optimum ignition timing thanks to intelligent replenishment management
- Automatic and on-demand ignition of the fuel with the aid of the HDG automatic ignition system (optional)
- Completely safe operation, as the ignition fan only starts when all doors on the boiler are closed

✔ Clever

- Intelligent HDG Control heating and system control with touch display (more on page 30)
- Read all information and configure settings for the entire heating system – can also be operated while wearing gloves
- Combustion and power control with the aid of a lambda sensor and flue gas temperature sensor



✔ User-friendly

- Easy movement of the fuel thanks to fuel chamber with a conical shape that expands downwards



- Clean and odourless conditions in the boiler room when opening the fuel chamber door thanks to integrated flue gas extraction
- Easy cleaning of the combustion grate by means of a sliding lever into the ash pan underneath



✔ Efficient

- Optimum combustion thanks to intelligent patented grate design



- Lowest emissions thanks to clean recombustion in the stationary high-temperature rotary combustion chamber

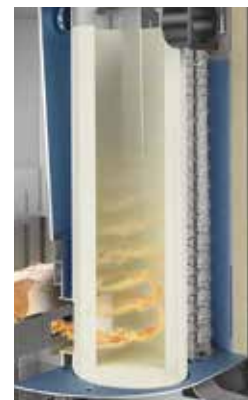

- Consistently high efficiency thanks to the integrated cleaning turbulators (can be operated from the outside)
- Automatic cleaning of the heat exchanger pipes by the HDG automatic cleaning system (optional)



✔ Independent

- Variable fuel use thanks to possible expansion with burner unit for (vegetable) oil – automatic switchover between log wood and oil operation
- Convenient operation, for example for frost protection or holiday mode
- Only one chimney required for both fuels
- In many cases, chimney renovation is unnecessary
- Advantageous for partial renovation of the heating system: cost and time savings, as the existing oil infrastructure (oil tanks, lines, etc.) can continue to be used

HDG H

Cross-section

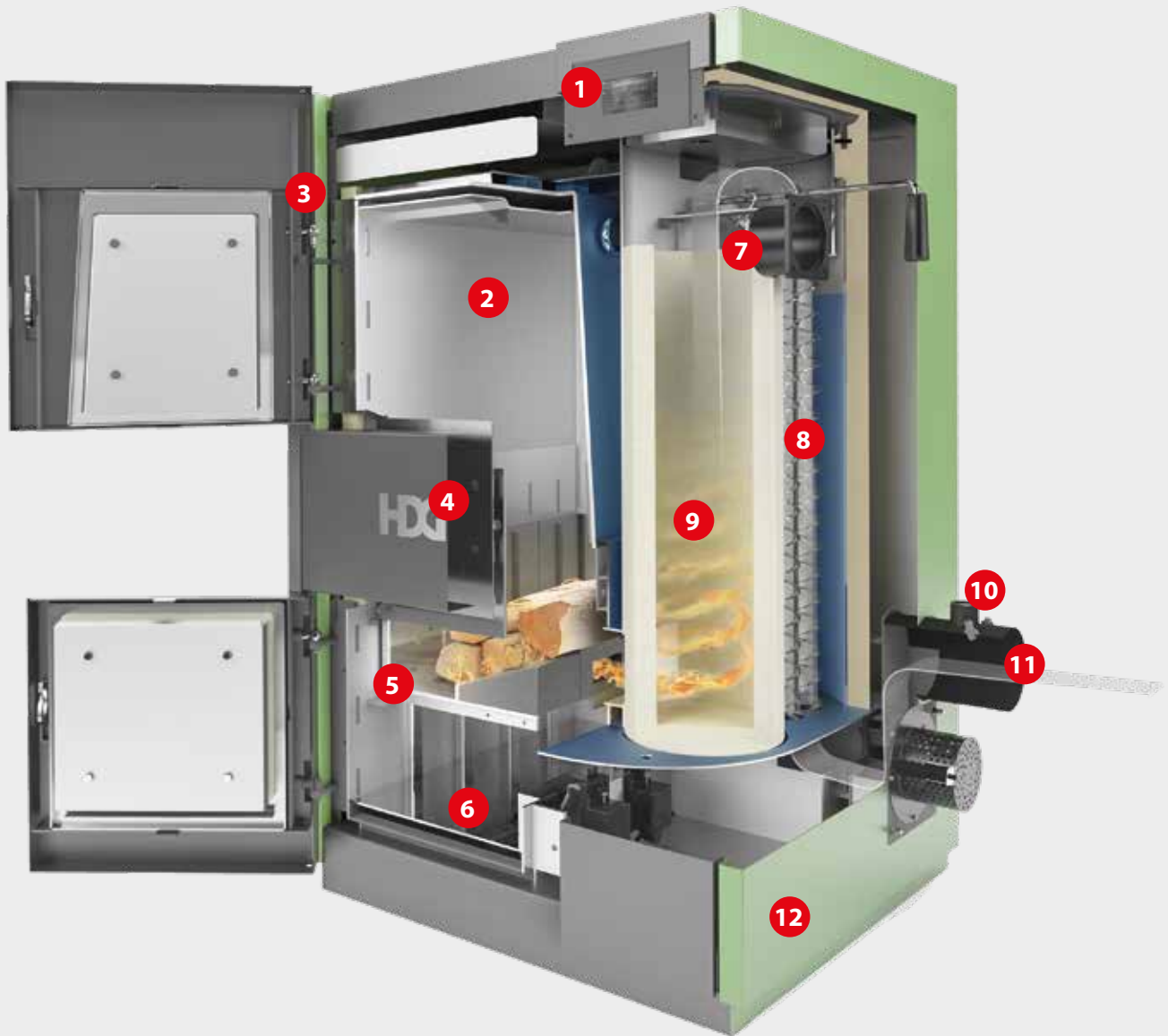

- 1 Intuitive HDG Control touch display (can also be operated while wearing gloves)
- 2 Large conical fuel chamber made from 8 mm quality steel sheet for long refuelling intervals
- 3 Flexible installation thanks to swappable door hinge
- 4 Actuators for primary and secondary air for precise air volume control
- 5 Easy to clean combustion grate
- 6 Large ash compartment with internal ash pan for effortless disposal of combustion residues
- 7 Standard flange for add-on oil burner unit

- 8 Cleaning turbulators for consistently high efficiency
- 9 Stationary rotary combustion chamber for low-emission recombustion of the fuel gases
- 10 Lambda sensor and flue gas temperature sensor as measured variables for low-emission combustion
- 11 Replaceable, low-lying flue gas pipe connection (can be mounted on the right or at the rear), also for chimney tapping at low height
- 12 Easy installation thanks to easy to mount cladding supplied separately

Technical data

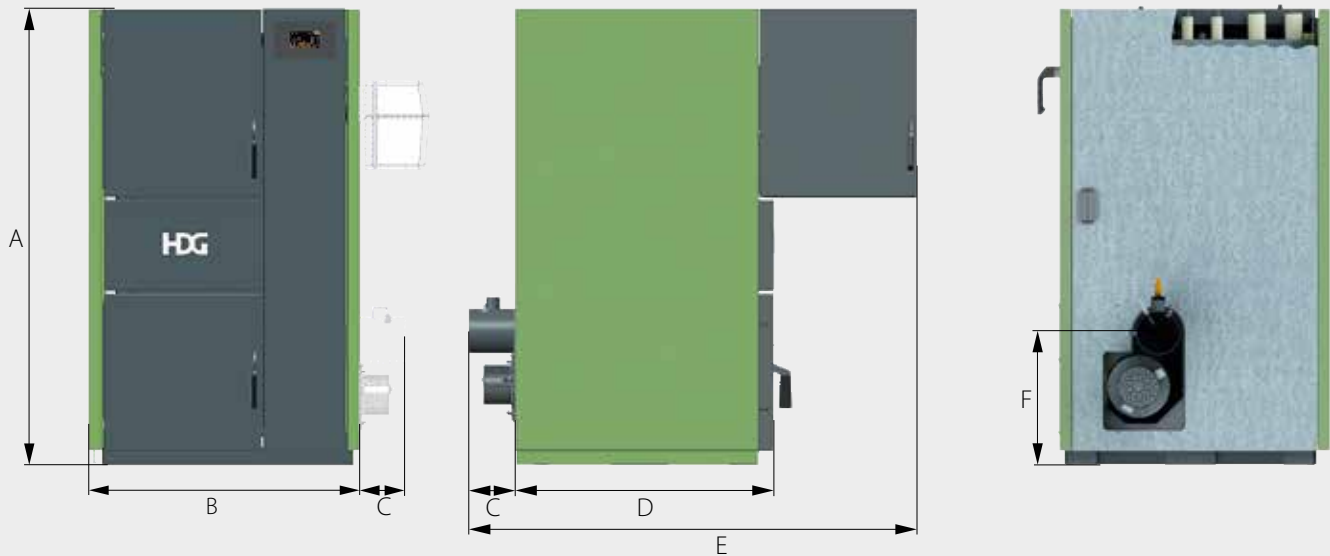

Dimensions (in mm)	Designation	HDG H20/25/30
A	Height of boiler (equates to height of flow/return connection)	1540
B	Width of boiler	910
C	Overhang of flue gas pipe connection	160
D	Total length with closed fuel chamber door without flue gas fan	870
E	Total length with open fuel chamber door with flue gas fan	1510
F	Height at middle of the flue gas pipe connection	450
	min. installation dimensions (without cladding and attachments)	755 x 845 x 1540

Boiler type	Unit	HDG H20	HDG H25	HDG H30
Nominal thermal power	kW	20	25	30
Fuel chamber capacity	l	165	165	165
Fuel chamber depth	mm	580	580	580
Dimensions of fill opening (width x height)	mm	320 x 380	320 x 380	320 x 380
Required auxiliary energy	W	49	51	53
Diameter of flue gas pipe connection	mm	150	150	150
Flue draught requirement (Pw)	Pa	10	10	10
Total weight	kg	680	680	680
Boiler energy efficiency class		A+	A+	A+
Boiler + controller energy efficiency class (class VI)		A+	A+	A+

HDG Euro

The all-rounder

The HDG Euro is a gasifying wood boiler, which has made a name for itself as a toplayer for the combustion of different wood fuels. The boiler, which has been tried and tested over 25,000 times, has been inspiring passionate wood heaters for two decades. In addition to log wood, it can also burn waste wood, wood chips, shavings or pressed wood briquettes, making it suitable for a wide range of applications.

Output:

30 kW, 40 kW, 48 kW

A+

Application range:

- Agricultural enterprises
- Single-family homes
- Apartment buildings
- Wood processing businesses
- Hotels and gastronomy
- Public Buildings



Fuels:

- Log wood (half a metre)
- Wood chips, shavings, pressed wood briquettes, waste wood in class 6 and 7*, for additional heating in conjunction with an optional HDG scale liner

* According to the 1st BImSchV (First ordinance for the implementation of the Federal Immission Control Act – Ordinance on Small and Medium-sized Firing Plants – valid in Germany) – painted, varnished and coated wood, plywood, chipboard, fibreboard or otherwise laminated wood and residues thereof (without organic halogen compounds or heavy metals, without wood protection agents) – permitted in wood processing and wood working businesses



Winner



German Federal Prize
for Innovation

"I am extremely satisfied with the robust boiler and tell my guests as much. If they are interested in heating with wood."

Hotel owner Anton Tauer



The highlights

✓ Robust

- Maximum life expectancy thanks to 10 mm fuel chamber wall made from quality steel sheet

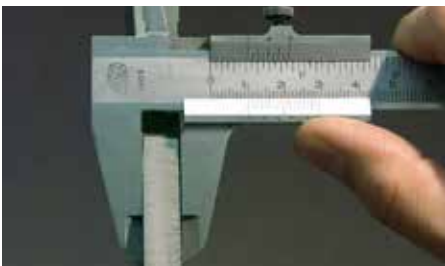

- Long durability of the air-cooled solid cast burner nozzle

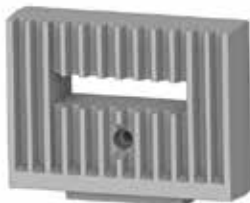

- Optimised boiler protection in the case of different fuel sizes thanks to scale liner (optional)



✓ Convenient

- Ideal fuel quantity and optimum ignition timing thanks to intelligent replenishment management
- Less frequent cleaning thanks to large and easily accessible cleaning openings
- Automatic and on-demand ignition of the fuel with the aid of the HDG automatic ignition system (optional)
- Completely safe operation, as the ignition fan only starts when all doors on the boiler are closed



✓ Efficient

- Maximum efficiency
- Optimum heat transfer thanks to large heat exchanger surfaces
- Lowest emissions thanks to clean recombustion in the stationary high-temperature combustion chamber



✓ Functional

- Less frequent firing up thanks to extremely large fuel chamber capacity
- Easy movement of the fuel thanks to fuel chamber with a conical shape that expands downwards
- Safe and ergonomic filling via the pneumatically assisted fuel chamber door with safety lock

✓ Clever

- Intelligent HDG Control heating and system control with touch display (more on page 30)
- Read all information and configure settings for the entire heating system – can also be operated while wearing gloves
- Combustion and power control with the aid of a lambda sensor and flue gas temperature sensor



✓ Versatile

- Suitable for a wide variety of wood types and sizes thanks to convenient filling from above
- Low-emission combustion of any fuel thanks to bottom lateral burning cycle
- Can be used in almost any area of application
- Height-adjustable, 3-part, solid combustion grate depending on fuel



HDG Euro

Cross-section

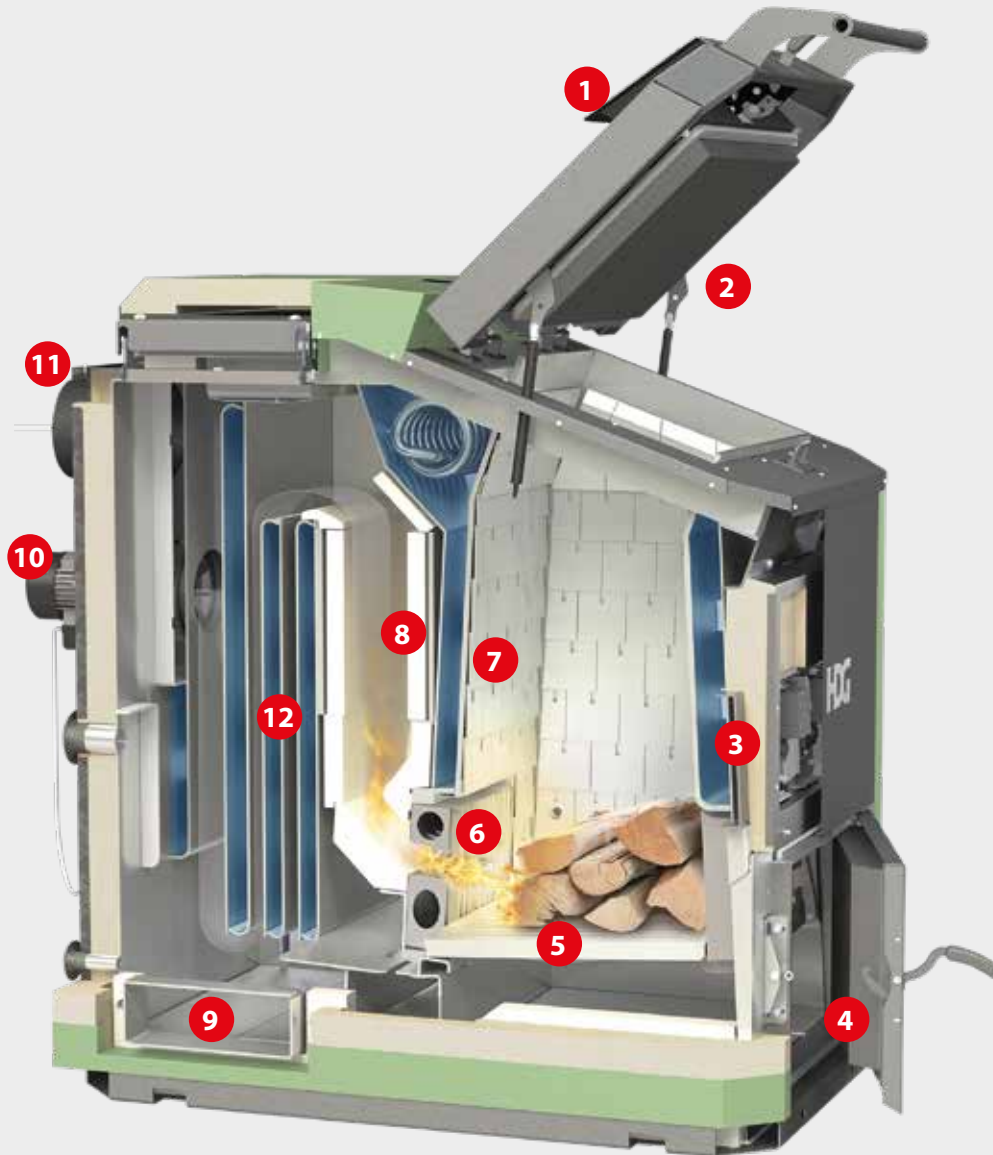

- 1 Intuitive HDG Control touch display (can also be operated while wearing gloves)
- 2 Pneumatically assisted fuel chamber door with safety lock
- 3 Actuators for primary and secondary air for precise air volume control
- 4 Ash door for large ash compartment (long cleaning intervals)
- 5 Extremely solid, height-adjustable cast iron grate with practical cleaning opening
- 6 Solid burner nozzle for mixing the secondary air

- 7 Robust conical fuel chamber made from 10 mm thick quality steel sheet
- 8 Modular, stationary combustion chamber for low-emission recombustion of the fuel gases
- 9 Cleaning openings on both sides for flue ash compartment
- 10 Low-noise flue gas fan
- 11 Lambda sensor and flue gas temperature sensor as measured variables for low-emission combustion
- 12 Large heat exchanger surfaces for optimum heat transfer

Technical data

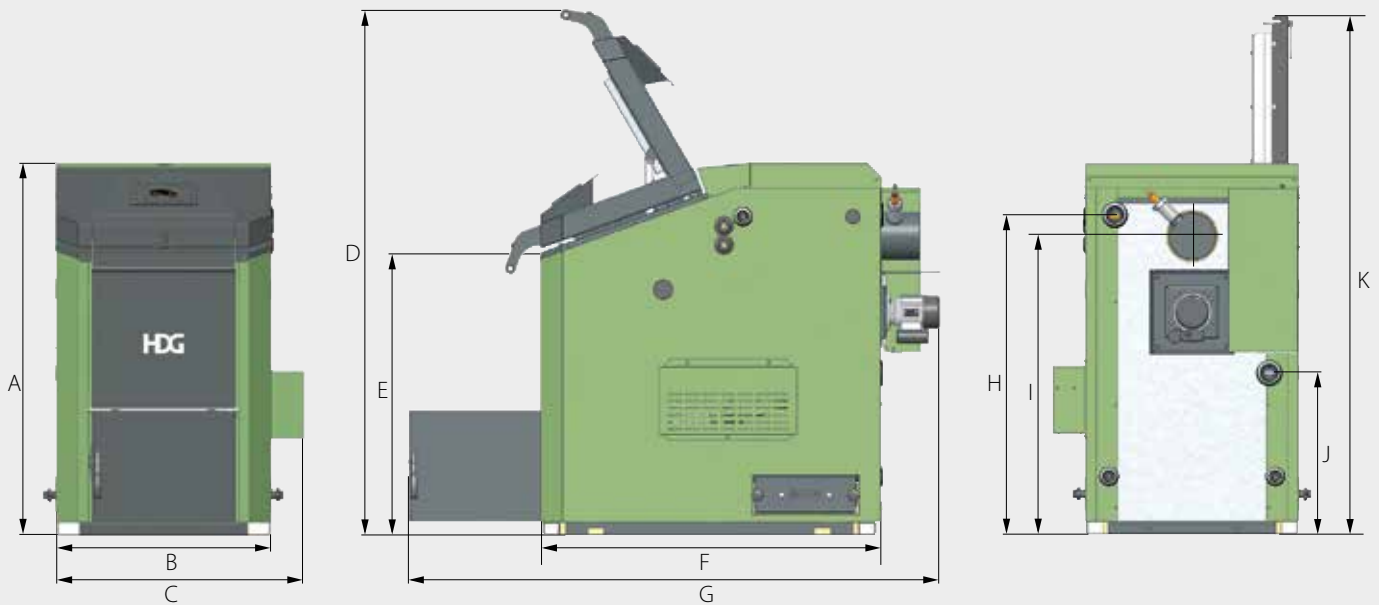

Dimensions (in mm)	Designation	HDG Euro 30/40/50
A	Height of boiler	1370
B	Width of boiler (without HDG automatic ignition system)	785
C	Width of boiler (with HDG automatic ignition system)	895
D	Height with open fuel chamber door	1990
E	Fuel chamber edge height	1110
F	Length of boiler without attachments and flue gas pipe connection	1260
G	Total length with open ash door including flue gas fan	1960
H	Height at middle of supply connection	1180
I	Height at middle of the flue gas pipe connection	1110
J	Height at middle of return connection	600
K	Height with open cleaning shaft lid	1920
min. installation dimensions (without cladding and attachments)		1395 x 785 x 1370

Boiler type	Unit	HDG Euro 30	HDG Euro 40	HDG Euro 50
Nominal thermal power	kW	30	40	48
Fuel chamber capacity	l	220	220	220
Fuel chamber width (without scale liner)	mm	560	560	560
Dimensions of fill opening (width x height)	mm	560 x 410	560 x 410	560 x 410
Required auxiliary energy	W	94	125	157
Diameter of flue gas pipe connection	mm	180	180	180
Flue draught requirement (Pw)	Pa	13	14	15
Total weight	kg	979	979	979
Boiler energy efficiency class		A+	A+	A+
Boiler + controller energy efficiency class (class VI)		A+	A+	A+

HDG F

The convenient one

The HDG F is a gasifying wood boiler of the latest generation with downward combustion technology. Its innovative design was awarded the iF DESIGN AWARD. It combines proven quality with innovative optimisations. The extremely large fuel chamber door makes it easier for the operator to work with the boiler on a daily basis. The very small footprint and convenient operation from the front also enable it to be used in small boiler rooms.

Output:

20 kW, 25 kW, 30 kW, 40 kW, 50 kW



Application range:

- Single-family homes
- Apartment buildings
- Agricultural enterprises



Fuels:

- Log wood (half a metre)



Awarded



"We previously had a 30 kW boiler. As the area to be heated has increased, we needed a log wood boiler with a greater output. When we visited the HDG plant in Massing, we were impressed by the 50 kW HDG F."

Bruno Drnovsek, Vehicle Service



The highlights

✔ User-friendly

- Less frequent firing up thanks to large fuel chamber capacity
- Flexible installation thanks to replaceable door hinge
- Ideal fuel quantity and optimum ignition timing thanks to intelligent replenishment management
- Automatic and on-demand ignition of the fuel with the aid of the HDG automatic ignition system (optional)
- Completely safe operation, as the ignition fan only starts when all doors on the boiler are closed



✔ High-quality

- Additional protection and easy movement of the fuel thanks to the edged panels with "anti-hollow fire" function



- Maximum life expectancy of the air-cooled 2-part solid burner nozzle made from cast stainless steel



✔ Clever

- Intelligent HDG Control heating and system control with touch display (more on page 30)
- Call up all information and configure settings for the entire heating system – can also be operated while wearing gloves
- Combustion and power control with the aid of a lambda sensor and flue gas temperature sensor



✔ Practical

- Can be used in almost any boiler room thanks to the space-saving dimensions and compact design
- Easy installation thanks to cladding supplied separately, which can be mounted without tools
- Less frequent cleaning thanks to large and easily accessible cleaning opening on the front

✔ Efficient

- Lowest emissions thanks to clean recombustion in the high-temperature combustion chamber
- Consistently high efficiency thanks to the integrated cleaning turbulators ① (can be operated from the front)
- Automatic cleaning of the heat exchanger pipes by the HDG automatic cleaning system ② (optional)



✔ Convenient

- Simple filling thanks to the largest fill opening amongst all comparable front-loading boilers on the market
- Convenient access for filling and cleaning in one single step (only one door each) thanks to innovative safety handle and XXL door insulation
- Time-saving "turbo heating" thanks to direct ignition via the burner nozzle
- Clean and low-odour conditions when opening the fuel chamber door thanks to integrated flue gas flap



HDG F

Cross-section

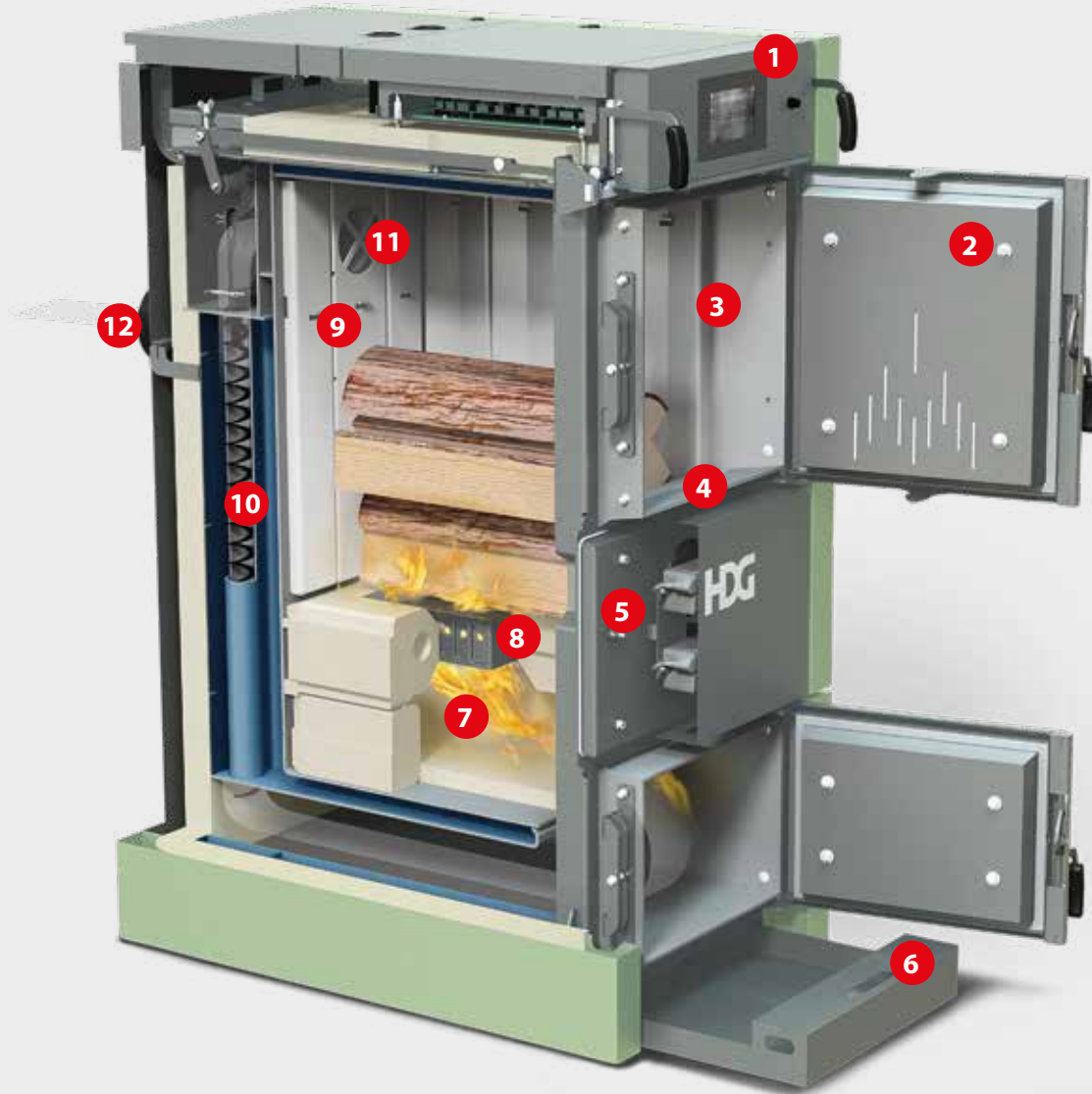

- 1 Intuitive HDG Control touch display (can also be operated while wearing gloves)
- 2 Extremely large fill opening for ergonomic filling and cleaning
- 3 Large fuel chamber for log wood up to 57 cm
- 4 Low filling edge for convenient filling
- 5 Actuators for primary and secondary air for precise air volume control
- 6 Integrated ash pan for effortless disposal of combustion residues

- 7 Modular combustion chamber for low-emission recombination of the fuel gases
- 8 Solid cast burner nozzle for optimum mixing of the secondary air
- 9 Edged panels to protect the fuel chamber wall and for easy fuel movement
- 10 Cleaning turbulators for consistently high efficiency
- 11 Flue gas flap for extracting the carbonisation gases in the fuel chamber
- 12 Lambda sensor and flue gas temperature sensor as measured variables for low-emission combustion

Technical data

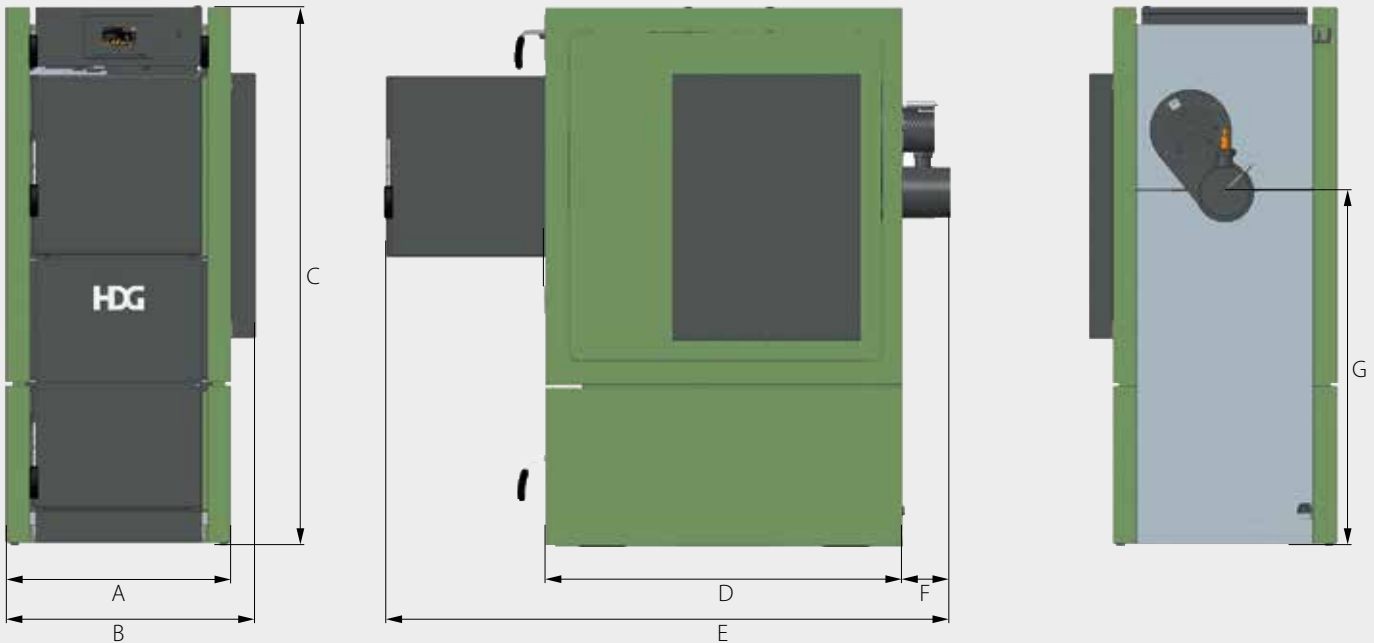

Dimensions (in mm)	Designation	HDG F20/25/30	HDG F40/50
A	Width of boiler (without HDG automatic ignition/cleaning system)	660	760
B	Width of boiler (with HDG automatic ignition/cleaning system)	730	830
C	Height of boiler (equates to height of flow/return connection top mounted)	1590	1650
D	Length of boiler without attachments and flue gas pipe connection	1050	1100
E	Total length with open fuel chamber door including flue gas fan	1655	1760
F	Overhang of flue gas pipe connection	140	140
G	Height at middle of the flue gas pipe connection	1040	1070
min. installation dimensions (without cladding and attachments)		1025 x 650 x 1585	1075 x 750 x 1645

Boiler type	Unit	HDG F20	HDG F25	HDG F30	HDG F40	HDG F50
Nominal thermal power	kW	20	25	30	40	50
Fuel chamber capacity	l	155	155	155	205	205
Fuel chamber depth	mm	570	570	570	570	570
Dimensions of fill opening (width x height)	mm	420 x 470	420 x 470	420 x 470	520 x 540	520 x 540
Required auxiliary energy	W	78	82	85	63	63
Diameter of flue gas pipe connection	mm	150	150	150	150	150
Flue draught requirement (Pw)	Pa	10	10	10	10	10
Total weight	kg	670	670	670	830	830
Boiler energy efficiency class		A+	A+	A+	A+	A+
Boiler + controller energy efficiency class (class VI)		A+	A+	A+	A+	A+

◆ HDG LOG WOOD/
PELLET COMBINATION

HDG FK Hybrid

The HDG log wood/pellet combination consists of the HDG F Hybrid gasifying wood boiler and the HDG K Hybrid pellet unit. This combines the advantages of a modern log wood boiler with the convenience of an automatic pellet boiler. The pellets are fed either manually or by means of an automatic pellet suction system. The pellet delivery system can be retrofitted at any time.

A+

Output:

Log wood range: 20 kW, 30 kW, 40 kW, 50 kW
Pellet range: 15 kW, 26 kW, 33 kW

Application range:

- Single-family homes
- Apartment buildings
- Agricultural enterprises



Fuels:

- Log wood (half a metre)
- Pellets

The flexible one



"We wanted to heat cheaply and flexibly with wood. This is the perfect solution, as the two special boilers are particularly environmentally friendly. Even for us as a young family, the log wood/pellet combination was affordable."

Matzinger family



✔ User-friendly

- Easy installation thanks to modular design
- Low-emission and efficient combustion thanks to separate combustion chambers for each fuel



✔ Convenient

- Simple filling thanks to the largest fill opening amongst all comparable front-loading boilers



- Ideal fuel quantity and optimum ignition timing thanks to intelligent replenishment management
- Automatic cleaning of the heat exchanger pipes by the HDG automatic cleaning system (optional)
- Automatic and on-demand ignition of the fuel with the aid of the HDG automatic ignition system (optional)



✔ Clever

- Intelligent HDG Control heating and system control with touch display (more on page 30)
- Combustion and power control with the aid of a lambda sensor and flue gas temperature sensor
- Advantageous thanks to considerable funding opportunities



✔ Flexible

- Cost-effective selection of fuel depending on the market situation and comfort requirements
- Automatic switching between log wood and pellet operation
- Pellet unit can be retrofitted at any time – without having to modify the boiler or the pipework
- Pellet reservoir can be filled manually or automatically

✔ Alternatives

- Two specialists – using the right boiler for every fuel
- Boilers can also be flexibly positioned in different rooms
- Flexible log wood/pellet combination, as the HDG K10-63 pellet boiler can be flexibly combined with any HDG log wood boiler
- Retrofitting is also easily possible at any time



HDG FK Hybrid

Cross-section



- 1 Intuitive HDG Control automatically switches between log wood and pellet operation
- 2 Large fill opening for ergonomic filling and cleaning
- 3 Two special combustion chambers for optimum combustion
- 4 Flue gas flap for extracting the carbonisation gases in the fuel chamber
- 5 Fully automatic cleaning of the pellet unit (optional for log wood boilers)

- 6 Large ash container for pellet units (either automatic or manual ash removal) or ash compartments for log wood boilers for long cleaning intervals
- 7 Easily accessible filling opening for the pellet reservoir (optionally with pellet suction system)
- 8 Large reservoir (107 kg pellets) for long filling intervals
- 9 Automatic ignition for the pellet unit (optional for log wood boilers)
- 10 Simple chimney connection when merging both flue gas pipes to form a shared connection

Technical data

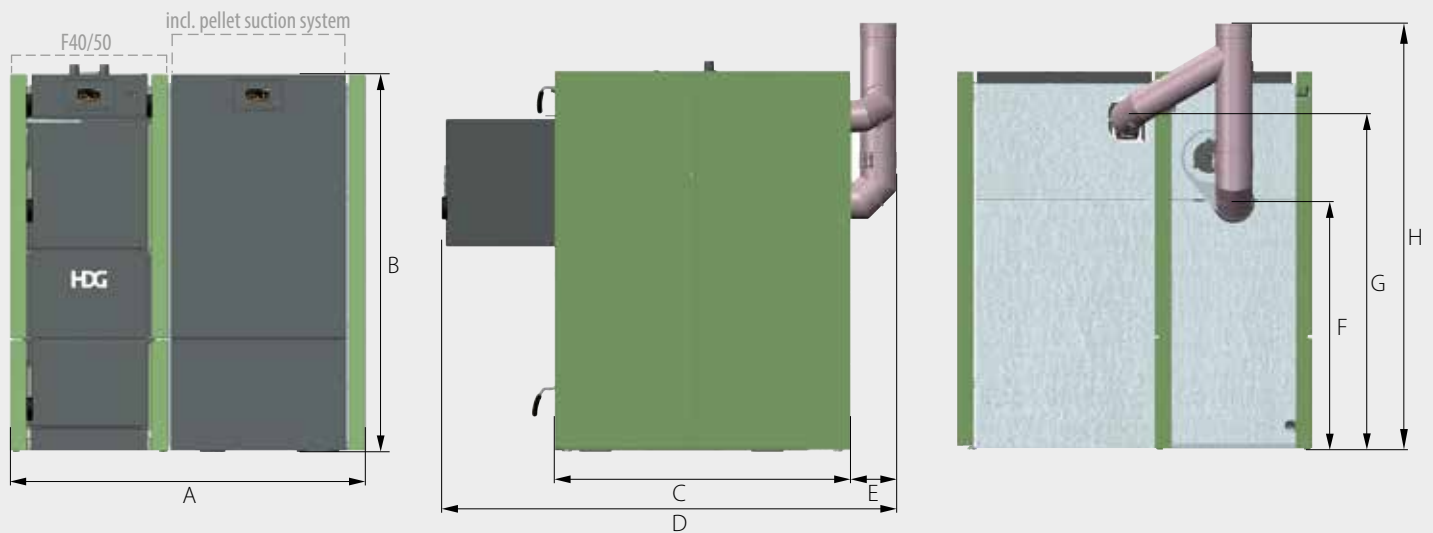

Dimensions (in mm)	Designation	HDG FK 20/15, FK 30/15, FK 30/26		HDG FK 40/26, FK 50/33	
		Manual filling	Pellet suction system	Manual filling	Pellet suction system
A	Width of boiler	1490	1490	1590	1590
B	Height of boiler (equates to height of flow/return connection)	1590	1730	1650	1730
C	Length of boiler without attachments and flue gas pipe connection	1230	1230	1230	1230
D	Total length with open fuel chamber door incl. flue gas pipe connection	1930	1930	2080	2080
E	Overhang of flue gas pipe connection	230	230	280	280
F	Height to centre of flue gas pipe connection (HDG F Hybrid)	1040	1040	1070	1070
G	Height to centre of flue gas pipe connection (HDG K Hybrid)	1390	1390	1390	1390
H	Height of flue gas pipe connection set	1780	1780	1810	1810

Boiler type	Unit	HDG FK 20/15	HDG FK 30/15	HDG FK 30/26	HDG FK 40/26	HDG FK 50/33
Nominal thermal power	kW	20 / 15	30 / 15	30 / 25.9	40 / 25.9	50 / 32.5
Fuel chamber capacity	l	155	155	155	205	205
Fuel chamber depth	mm	570	570	570	570	570
Dimensions of fill opening (width x height)	mm	420 x 470	420 x 470	420 x 470	520 x 540	520 x 540
Required auxiliary energy	W	78 / 33	85 / 33	85 / 48	63 / 48	63 / 77
Diameter of flue gas pipe connection	mm	150	150	150	150	150
Flue draught requirement (Pw)	Pa	10 / 5	10 / 5	10 / 5	10 / 5	10 / 5
Total weight	kg	830	830	850	1100	1100
Boiler energy efficiency class		A+ / A+	A+ / A+	A+ / A+	A+ / A+	A+ / A+
Boiler + controller energy efficiency class (class VI)		A+ / A+	A+ / A+	A+ / A+	A+ / A+	A+ / A+

HDG Control

The intelligent one

Heating and system control

The new HDG Control is the intelligent control centre for your entire heating system. The intuitive control has a user-friendly, robust touch display that can even be operated with gloves. The design of the control system and the operation are clearly and comprehensibly structured. The wide range of functions can be individually adapted.

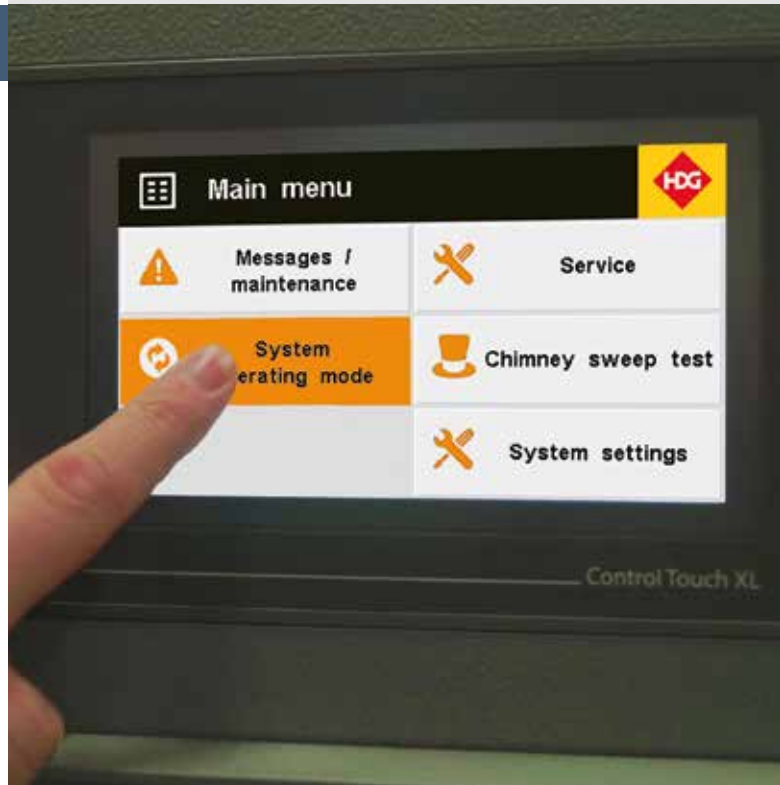

✓ Versatile functions

The combustion and power control of the log wood boiler is carried out with the help of the lambda probe and the flue gas temperature sensor. In addition, the HDG Control also regulates the complete heating system: Accumulator, external heat source, heating circuits, mains pumps, domestic hot water tank, solar system.

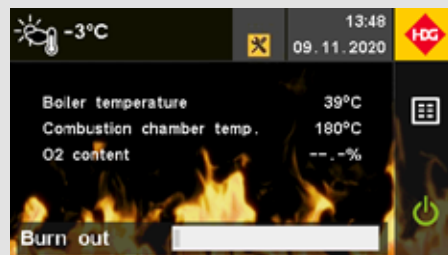

Clear presentation of the most important system data at a glance

HDG replenishment management

✓ Refuel less frequently

The HDG Control continuously monitors the charging degree of the accumulator. Depending on the outside temperature and the current consumer demand, the next ideal time to add wood is calculated and displayed. This makes the best possible use of the energy and reloading is required less often.



Easy-to-understand, graphical overview even for complex systems

✓ Efficient use of wood

By displaying the replenishment quantity, only as much wood is burned as can be efficiently processed. No log is wasted.

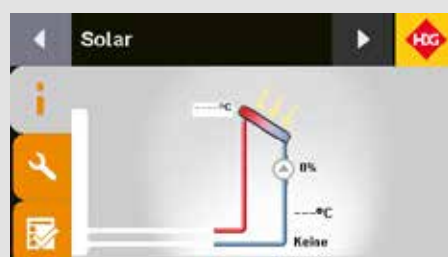

Integration of further heat sources such as solar systems or oil/gas boilers

HDG Control web visualisation – the large display with web access



The HDG Control is available with web visualisation on request. Thanks to the web server integrated in the display, the heating system can also be accessed on the move using a smartphone, PC or tablet. In addition, an enlarged 7" display is included here instead of the standard 4.3" display. HDG Control thus offers full access to the heating system in addition to even better readability.

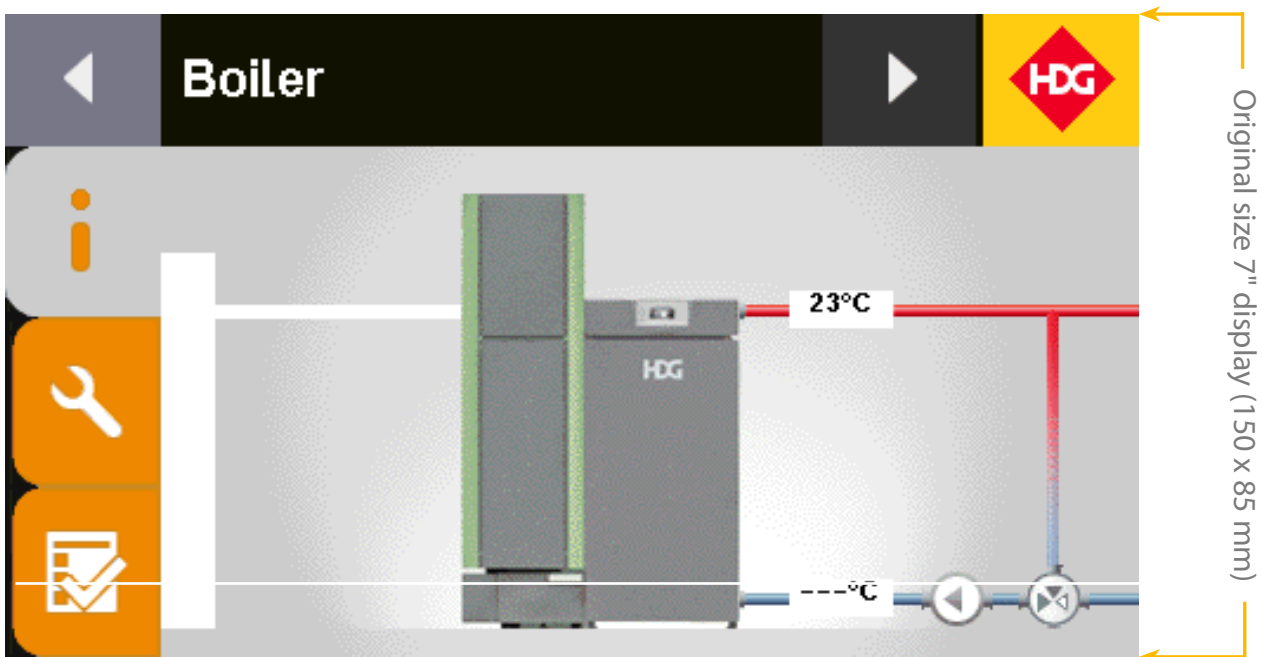

THE HEATING SYSTEM IN YOUR POCKET

Do you want to view the heating system on the screen with the click of a mouse or change settings with a simple tap on a smartphone or tablet? With myHDG, this can be done quickly and easily at any time.

- Quick set-up of web access via the free communication portal myHDG
- The system fully under control thanks to simple, graphic display
- Same operation structure as on the HDG boiler
- Query and change all parameters, e.g. operating status, temperature, etc.
- Messages are conveniently sent by e-mail
- With myHDG you can also manage several systems with just one access



THE HDG DATA PROTECTION TIP

HDG provides full data protection – all data remains only on your system. Data transmission is secure via HTTPS. Direct access within the network (without connection to the outside) is also possible.

HDG Control

HDG Hydraulic Systems – Individual planning for your system

HDG plans the right system for your individual requirements. A hydraulic diagram with a suitable terminal plan is provided for each system for easy installation. For commissioning, the number of the diagram is sufficient to configure the controller accordingly. The following illustration shows the possible basic equipment for a touch control unit. Extensions are possible at any time.

Accumulator

- Control of up to two accumulator systems
- Intelligent replenishment management shows ideal replenishment time and optimum replenishment quantity
- Easy combination of existing or different sized accumulators thanks to the HDG reloading system

Heating circuits

- Control of up to six heating circuits
- Outdoor-temperature-controlled with different operating modes and individual weekly programs (normal, day, night, party, holiday, off)
- Various room control units/room sensors depending on the requirements for controlling the living room temperature

Efficient combustion control

- The HDG Control controls the complete combustion of the log wood boiler
- Determination of the optimum air volume via flue gas temperature sensor and lambda sensor and control via flue gas fan, primary and secondary air actuators
- This results in optimum efficiency and best possible fuel utilisation even with changing fuels



External heat source

- Control of an external heat source (e.g. oil/gas boiler or electric heater)
- Heat source is possible via the accumulator with base or peak load function or directly to the consumers as an emergency load boiler
- Individual weekly programmes for setting enable times

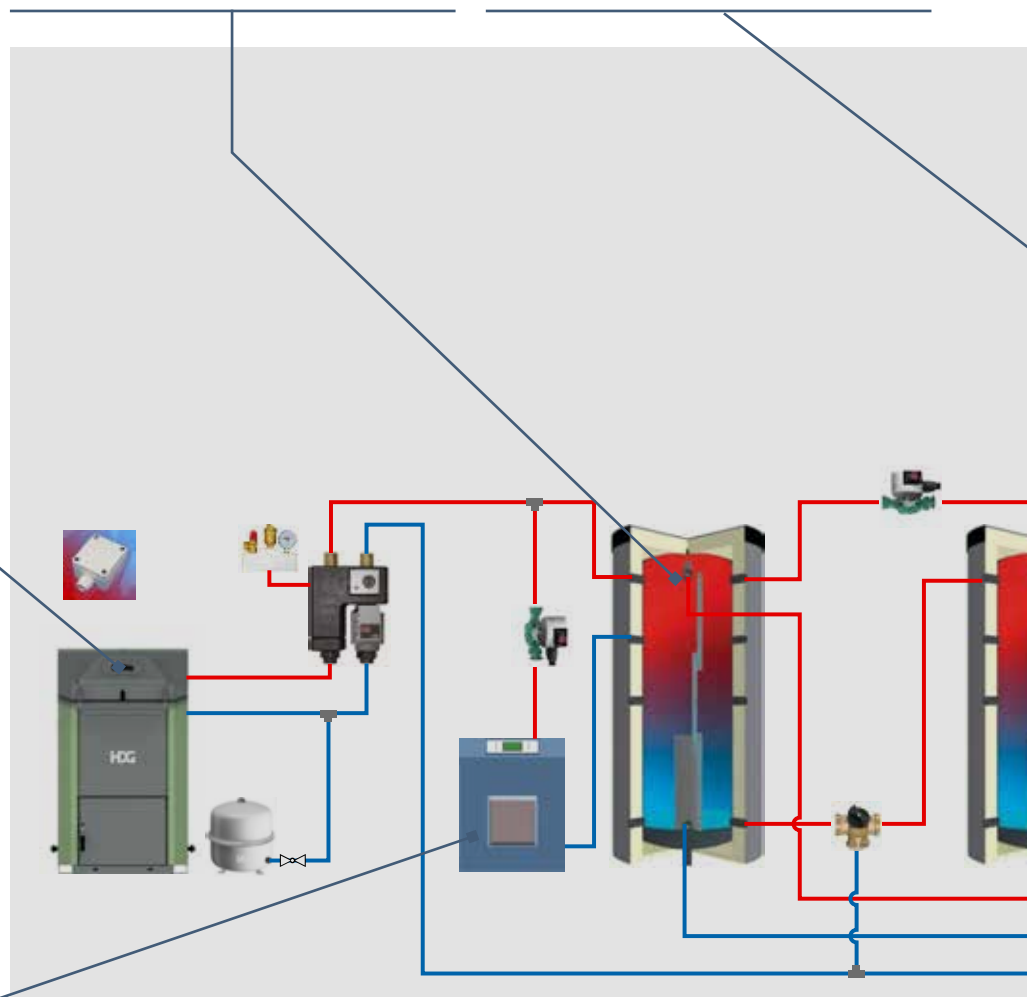

Network pump

- Control of up to two network pumps for local heating networks
- Only active when heat is requested by the heating components
- Up to twelve different control variants possible



Solar thermal system

- Control of a solar thermal system with a maximum of three zones
- Versatile with up to 20 variants possible on domestic hot water tank and/or accumulator
- High efficiency thanks to speed control of the solar pump by means of PWM signal
- Alternative integration of PV systems possible



Domestic hot water preparation

- Control of up to two external domestic hot water tanks
- Versatile thanks to individual weekly programs
- Safe thanks to protection from Legionnaire's disease and domestic hot water priority
- Alternatively, domestic hot water preparation also possible directly integrated into the accumulator or externally via fresh water station

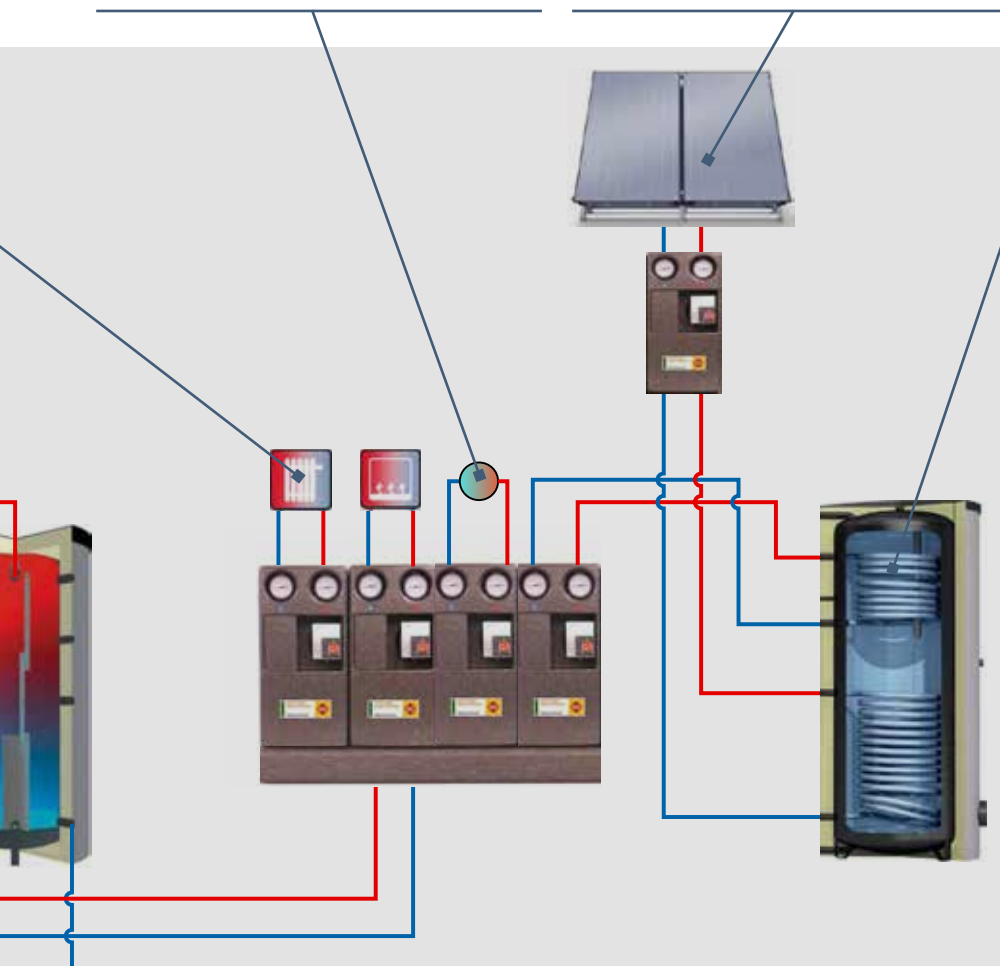

HDG hydraulic finder

HDG revolutionises hydraulic planning!

With the HDG hydraulic finder, specialist companies can perform the complete hydraulic planning including the terminal diagram – at any time and completely free of charge.

The HDG hydraulic finder can be found on the HDG website and already accesses over **3,000 hydraulic diagrams**. Unique on the market, this innovation from HDG revolutionises common hydraulic planning.



Heat from wood

Convenient and environmentally friendly storage



An accumulator represents the central heat supply of a heating system. It absorbs energy from the boiler and releases it back into the heating system as required. HDG accumulators compensate for reduced and peak outputs, reduce boiler running times

and guarantee constant and thus energy-saving operation of the heating system. HDG accumulators meet all comfort requirements and improve the overall efficiency of the heating system.

Accumulators for log wood boilers

To achieve a high level of comfort and long refuelling intervals, the size of the accumulator must be matched to the boiler type, the type of wood and the heat demand of the building.

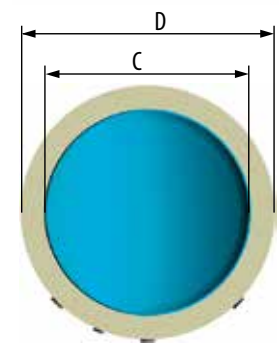
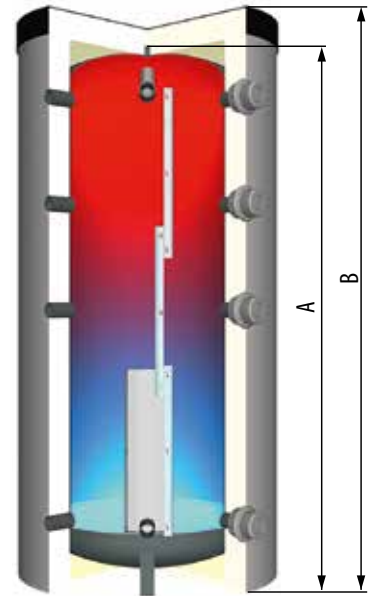

Top view

HDG rule of thumb for minimum accumulator volume

Boiler	Minimum accumulator volume
HDG R15	1000 l
HDG H20/25/30	2000 l
HDG Euro 30/40/50	3000 l
HDG F20/25/30	2000 l
HDG F40/50	3000 l

Softwood:

Fuel chamber capacity in litres x (12 to 15) = Minimum accumulator volume

Hardwood:

Fuel chamber capacity in litres x (15 to 18) = Minimum accumulator volume

Dimensions Volume	A mm	B mm	C mm	D mm	Tilt height mm	Nominal capacity l	Heat retention losses W	Energy efficiency class
500	1627	1693	650	850	1640	476	101	C
825	1820	1886	790	990	1834	828	134	C
1000	2020	2086	790	990	2033	930	142	C
1250	1741	1807	990	1230	1754	1206	158	C
1500	2091	2157	990	1230	2110	1507	171	C
2000	2247	2313	1100	1340	2270	1904	187	C
2500	2315	2405	1250	1490	2409	-	-	-
3000	2615	2705	1250	1490	2680	-	-	-
3150	2378	2468	1400	1640	2492	-	-	-
4000	2928	3018	1400	1640	2988	-	-	-
5000	2755	2839	1600	1840	2891	-	-	-
6000	3255	3339	1600	1840	3340	-	-	-
7000	3749	3869	1600	1840	3861	-	-	-
8000	4249	4369	1600	1840	4325	-	-	-
9000	4749	4869	1600	1840	4797	-	-	-
10,000	5249	5339	1600	1840	5273	-	-	-

HDG – a family company

1978



HDG founded by Karl Ackermann

1981



The company grows steadily

1990



Eva Ackermann, the youngest daughter of the company founder, joins the company

The legendary HDG Bavaria log wood boiler goes into series production



1978

HDG now also develops wood boilers for wood chips



1988

The HDG Euro log wood boiler celebrates its première



1996

The first boiler specifically for pellets



2002



1978



2016

Since 1978, we have been combining **innovative thinking with sustainable action**, advocating **climate-friendly heat generation** and developing versatile products and services for a wide range of applications.

2005



Foundation stone laid for the construction of the new HDG administration building

2006



Completion of the administration building

2014



Foundation stone laid for the construction of the new logistics centre

New design line is introduced and awarded 1 year later

Expansion of the entire boiler range in terms of design, performance and technology

The HDG M series grows. HDG M175-240 wood chip boiler – innovative, cutting-edge technology available for the first time in the medium power range

New generation of the HDG Compact 30-95(E) wood chip boiler with innovative extensions



2014



2016



2018



2020

This is based on **well-engineered and durable products, detailed and honest advice, individual support** in planning the heating system and, last but not least, responsible action and **human appreciation** towards customers and colleagues.

As a Bavarian family business, we are proud to produce in the region and thus be able to offer our prospective customers flexible solutions "Made in Germany" – over 100,000 satisfied customers speak for themselves. Today, around 200 HDG employees live this philosophy.

HDG has become so successful because people trust both the boilers and staff from Massing.

Sustainability in action



For our environment

Thanks to ongoing further development of our HDG technology, our boilers meet the strictest emission limits with the highest efficiency levels.

Many have been awarded innovation prizes by the kwf and the Federal Republic of Germany. Efficient technology with maximum heating comfort is just as important to us as the sustainability of our products.

HDG is committed to a **positive environmental balance** and has been for many years.

- Environmental and quality management have been practised at HDG for many years
- GOGREEN – mailing via DHL
- Energy from 100% local, environmentally friendly hydropower
- Green-IT – use of resource-saving information technology
- Member of the Bavarian Environmental Pact
- We are supporters of GEMEINWOHL-ÖKONOMIE (greater good economics)

Awarded



HDG – 100% service

We accompany you from consultation to customer service for your perfect HDG heating system.



Our expert advisors will advise you free of charge – on site, of course – and will also be happy to inform you about current funding opportunities



Thanks to our regional production we can also offer you individual special solutions



Our comprehensive factory customer service guarantees the highest level of expertise and provides fast and reliable assistance at all times



Individual planning and support also for your heating engineer



Service is a top priority at HDG: Delivery, assembly, commissioning and more – you receive all services from a single source



Reliable spare parts supply – a matter of course for HDG

Energy labelling for wood boilers

Since 1st April 2017, energy efficiency labelling within the framework of the Ecodesign Directive has also applied to wood boilers. Accordingly, all HDG boilers up to 70 kW and compound systems consisting of boiler, temperature controller, solar system and accumulator must meet the efficiency requirements and be labelled accordingly.

All HDG boilers achieve above-average efficiency classes, both on their own and in combination.

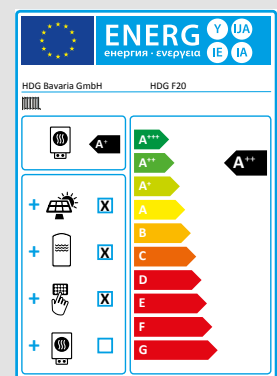



HDG Bavaria GmbH
Heating system for wood

Siemensstrasse 22
84323 Massing, Germany

Tel. +49 (0) 8724 897 0
Fax +49 (0) 8724 897 888 100
info@hdg-bavaria.com

Visit us at:



**Perfect wood boilers for every application
from 10 to 800 kW**

- Log wood boiler
- Wood chip boiler
- Pellet boiler
- Combined boiler for log wood/oil or for log wood/pellets
- Heat + power from wood – energy concepts with wood gasification
- HDG accumulator and system components

